

Guardian

Portable Hydraulic Filtration Systems

Max. 15 l/min - 3.4 bar



Making portable system cleanliness available all the time

A 'use anywhere' fluid transfer solution

The Guardian portable filtration system is designed to 'clean' new oil and deliver it to a system or carry out a clean up of used fluid to its original condition. Maximum pressure 3.4 bar. Maximum flow 15 l/min. A water removal element option is also available.



Contact Information:

Parker Hannifin
Hydraulic Filter Division Europe

European Product Information Centre
Freephone: 00800 27 27 5374
(from AT, BE, CH, CZ, DE, EE, ES, FI, FR, IE, IT, PT, SE, SK, UK)
filtrationinfo@parker.com

www.parker.com/hfde

Product Features:

- Guardian is designed to 'clean' new oil and deliver it to a system.
- Carries out a clean up of existing fluid to its original condition.
- Maximum pressure 3.4 bar. Maximum flow 15 l/min.
- Filters petroleum based oils, water emulsions and diesel fuels.

Guardian

Portable Hydraulic Filtration Systems

Features & Benefits

Features	Advantages
Portable and robust design	Guardian is designed to be used anywhere. Take it to the system or transfer new oil from the drum.
Lightweight design	Only 10.6 kg
Quick disconnect hose connections	Storage is simple. Guardian's compact design means it is easily stowed.
Visual indicator	Operational condition is constantly monitored
110VAC or 220/240VAC options	Guardian's power flexibility means it can be used anywhere.
A range of clean-up elements	A user can specify the media that will best achieve his clean up/filtering requirements.
Water removal element option	Water removal from the system is an important requirement for fluid efficiency.

Note: 15 l/min / Fluid transfer at a controlled rate

- Fluid transfer
- Offline reservoir clean-up
- Injection moulding machines
- Royal navy surface fleet systems
- Paper mills
- Industrial equipment
- Mobile equipment
- Marine system support

The Parker Filtration Guardian portable filtration systems.

Guardian is a portable filtration system with two main functions: to ensure that new 'dirty' fluid often contaminated during handling, is delivered to the system at a specific cleanliness; and to permit periodic clean up of existing fluid to original condition.

Recommended fluids: Petroleum based oils, water emulsions and diesel fuels.

Application Example

A hydraulic system reservoir had become heavily contaminated and the hydraulic system was in danger of a catastrophic failure from particulate and water contamination. These contaminants were introduced from various points – airborne, wear and introduction of new 'dirty' fluids. The Guardian filtration system was installed into the hydraulic systems reservoir and run completely off-line for a period of time until acceptable contamination levels were achieved.

This off-line attachment allowed the hydraulic system to continue operating without costly downtimes. Additionally a Water Removal (WR) Element was also fitted to the Guardian, which radically reduced the water contamination within the entire system.

This customer will 'only now' introduce new fluids into his hydraulic application by using the Guardian filtration system and in addition utilises the Guardian off-line option to maintain and protect his system.

Contamination levels are monitored by an LCM202022 which controls the Guardians operation.

Result: reliability and complete confidence restored.



Specification

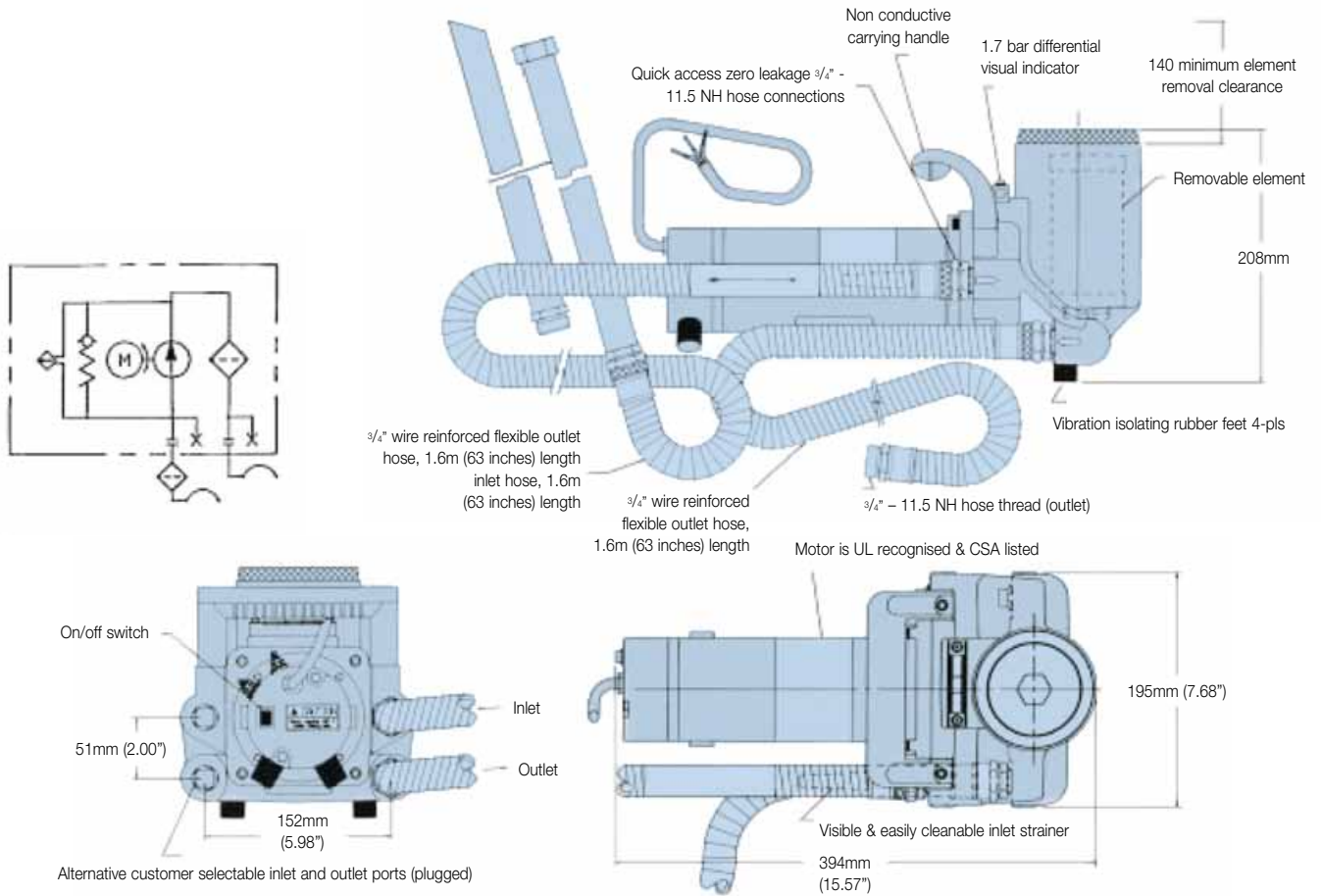

Guardian

Portable Hydraulic Filtration Systems

Ordering Information and Product Configurator

Standard products table

Part number	Supersedes	Model (fluorocarbon)	Motor option	Element (μ)	Options	Plug type	Replacement element
GT4E110Q1UK	F3-GT4E-1-10Q-1-UK	GT4E	1	10Q	1	UK	G04396Q
GT4E110Q1EUR	F3-GT4E-1-10Q-1-EUR	GT4E	1	10Q	1	EUR	G04396Q
GT4E210Q1IND	F3-GT4E-2-10Q-1-IND	GT4E	2	10Q	1	IND	G04396Q

Note 1: Motor Options*

Option 1 = 220/240 VAC

Option 2 = 110 VAC.

Note 2: Plug Type**

IND = Industrial 110VAC UK Option.

Note 3: (Options) Quick disconnect hose connections are available. Consult Parker.

Note 4: The 24 Volt motor option is available. For details consult Parker.

Replacement elements

Guardian replacement elements to ISO16889

Part number	Media code	Media type
G04396Q	10Q	Microglass III
G04394Q	02Q	Microglass III
G04395Q	05Q	Microglass III
G04397Q	20Q	Microglass III
G04400	25	Wire mesh
G04401	40	Wire mesh
G04402	74	Wire mesh
932019	WR	Water removal

Note 1: Part numbers featured with bold highlighted codes will ensure a 'standard' product selection.

Note 2: Alternate displayed part number selection will require you to contact Parker Filtration for availability.

Filtration Unit

Hydraulic Service Equipment

Max. 15 l/min - 6 bar



Permanent and offline fluid cleaning

Reliable fluid transfer from drum to system

The Filtration unit offers both permanent and offline fluid cleaning where higher levels of contamination are expected. Maximum pressure 6 bar. Maximum flow 15 l/min. Designed to take the unit to the application for maximum efficiency in use.



Contact Information:

Parker Hannifin
Hydraulic Filter Division Europe

**European Product
Information Centre**
Freephone: 00800 27 27 5374
(from AT, BE, CH, CZ, DE, EE, ES,
FI, FR, IE, IT, PT, SE, SK, UK)
filtrationinfo@parker.com

www.parker.com/hfde

Product Features:

- Filtration unit offers both permanent and offline fluid cleaning where higher levels of contamination are expected.
- Lightweight design. Spin-on 10 micron Abs. element.
- Maximum pressure 6 bar. Maximum flow 15 l/min.
- Robust construction.

Filtration Unit

Hydraulic Service Equipment

Features & Benefits

Features	Advantages	Benefits
Single phase and three phase motor options	Flexibility of power output	End user choice dependent on application
15 l/min flow	Fluid transfer at a controlled rate	Reliable fluid transfer from drum to system
Red/green visual indicator	Clear indication of condition during operation	High visibility during operation
Robust construction	Reliability designed in	Designed to be used even in the most demanding conditions
Spin-on element	Easy change element	10 micron Abs. elements
Lightweight design	Easy to locate when and where required	Take the unit to the application. It's that easy

Typical Applications

- Fluid transfer
- Small lubrication systems
- Constant flushing loops
- Maintenance flushing
- Offline filtration in circuits where pressure and flow pulses are expected

The Parker Filtration Service Equipment.

Designed to offer both permanent and offline cleaning where higher levels of contamination are expected and portable additional clean-up capability as part of your preventative maintenance package.



Specification

Electric motor

Frame Size: IEC Frame 63. Foot and flange 'D' (Flange IEC.F115). Totally enclosed fan cooled.

Windings: 380/420 volt 3 ph/50 Hz, 220 Volt 1 ph/50 Hz 110 Volt 1 ph/50 Hz.

Power: 0.18 kW (1/4 hp).

Speed: 1400 rev/min.

It is recommended that the Unit is wired independently from the main system when permanently installed, to facilitate the simple changing of the filter element without interrupting the main system.

Filtration unit description

The Parker 'Filtration Unit' consists of an electric motor directly coupled to a hydraulic pump, which has a built in bypass fitted and spin on filter element. Fluid drawn in at pump inlet is circulated through the filter element and is thus cleaned before being delivered from the outlet port. A built in bypass valve safeguards the element in the event of blockage and returns oil to the pump inlet, this ensures that all fluid output from the unit is filtered, whatever the operating conditions. A visual element condition indicator is fitted to the pump. A unit is available without electric motor for customers who prefer to supply their own. See installation notes and part numbers for ordering.

Pump and bypass valve

Pump: Lobe type for quiet running.

Flow: 15 l/min.

Connections: Inlet G¹/₂ (1/2" BSP).
Outlet G³/₈ (3/8" BSP).

Bypass Valve: Cracks at 1.5 bar approximately. Bypassed oil is recirculated within the pump. Bypassed oil is reintroduced into the inlet port and does not pass the filter. Bypass operates when the element is contaminated and needs replacing. This condition will be made clear by the visual indicator. The Bypass Valve could also open when being used with high viscosity fluids, thus effectively reducing the unit output.

Filter and condition indicator

Filter Type: Rapid replacement spin-on can with 10µ cellulose element. Ensure that end clearance (20mm) is available to permit element withdrawal. 10µ absolute. MXR8550

Visual indicator

Has green and red zones on the dial. Needle in the green zone indicates normal operation. When the needle enters the red zone, the bypass valve will permit a flow of oil to return to the pump inlet – The element will then need to be replaced. The bypass is fully open when the needle is at the extreme of the red sector.

Sound level

The Filtration Unit under normal conditions will operate at a sound pressure level of approximately 65 dBA.

Installation Details

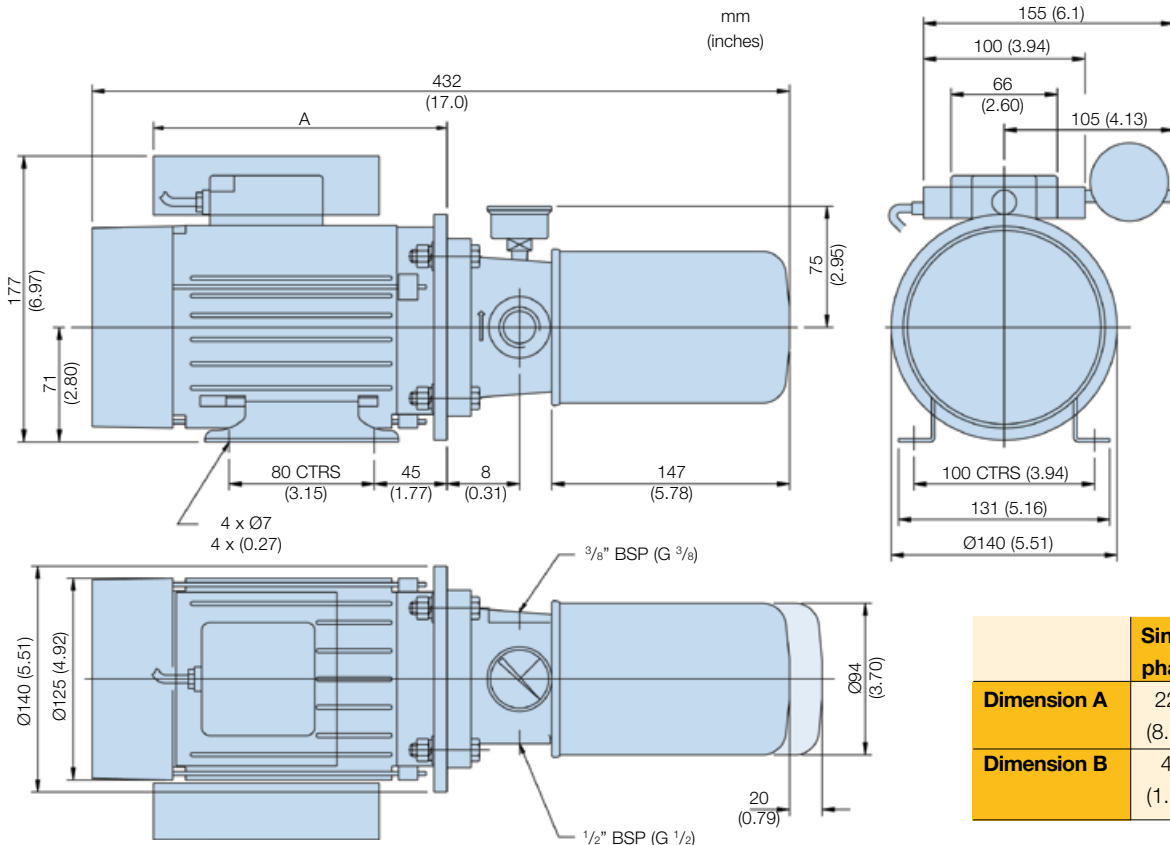

Filtration Unit

Hydraulic Service Equipment

Sectioned Detail

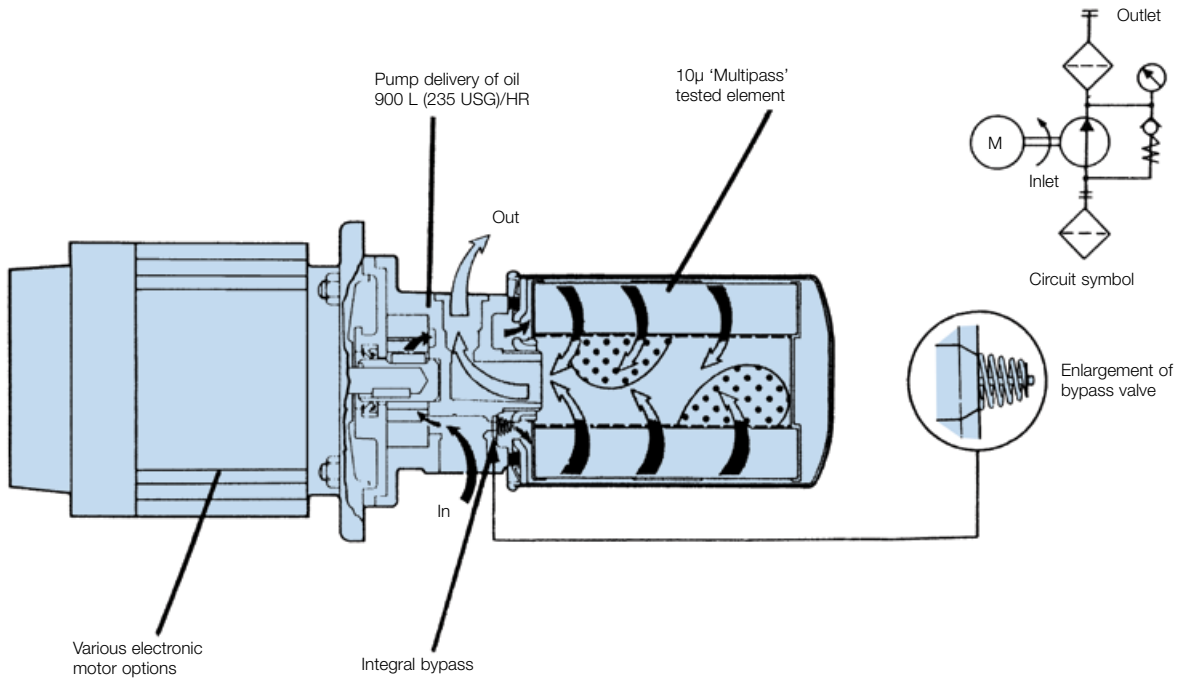

Installation and Operational Notes

The Filtration Unit is suitable for mineral based oils. Maximum viscosity at start up condition 850 centistokes-minimum viscosity 8 centistokes. Note that at 850 centistokes output will be reduced due to opening of bypass. Maximum operating temperature +90°C (194°F).

The inlet pipe should be as large and as short as convenient to reduce inlet depression to a minimum. It should not be less than 12mm (0.47") internal diameter.

Suction element SE7511110 is supplied with all assemblies and must be installed. Ensure that a minimum 75mm (2.95") head of oil is maintained above the suction element.

The outlet pipe should be as large as possible to reduce the possibility of delivery pressure exceeding the bypass valve setting. It should not be less than 10mm (0.39") internal diameter. The discharge end of this pipe should always be below the oil surface to minimise aeration. It is equally important, to ensure the ends of the inlet and outlet pipes are as far apart as possible. It is recommended that a baffle be positioned between the suction and return pipes, to give maximum circulation of oil.

Installation details – 2742

The Filtration Unit is available without an electrical motor, any type motor may be used of identical frame, flange and shaft size to that stated in the specification. Remove the key, fitted to electric motor shaft. There are four nuts and bolts M8-1.25mm thread supplied loose, the pump housing is complete with a shaft adaptor with internal drive pin.

To fit pump to electric motor simply insert drive shaft of motor into the pump drive adaptor ensuring the drive pin engages in shaft keyway and that the locating spigot are correctly engaged. Complete the assembly by fitting the four nuts, bolts and washers.

Ideal Application

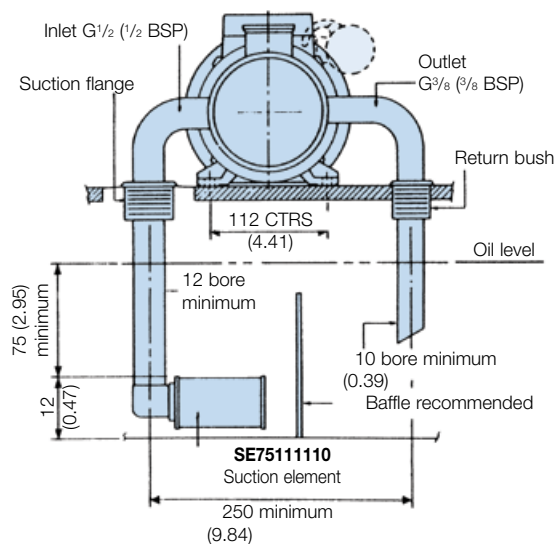
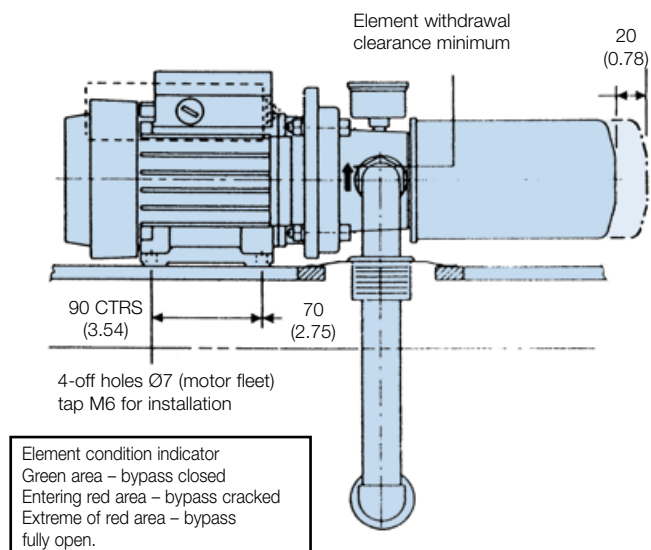

Ordering Information

Standard products table

Part number	Description	Weight	Replacement elements
2741	10µ abs. filtration pump complete with 3 phase electric motor (380/420/50 Hz H.E.F.C class F) visual indicator	5.92 Kg (13.02 lbs)	MXR8550 (10µ abs.)
2742	10µ abs. filtration pump without electric motor (supplied with 4 x nuts, bolts and washers) visual indicator	1.50 Kg (3.3 lbs)	
2743	10µ abs. filtration pump complete with single phase electric motor (220/50 Hz T.E.F.C class F) visual indicator	6.20 Kg (13.64 lbs)	
2744	10µ abs. filtration pump complete with single phase electric motor (110/50 Hz T.E.F.C class F) visual indicator	6.20 Kg (13.64 lbs)	

Note 1: Part numbers featured with bold highlighted codes will ensure a 'standard' product selection

Note 2: Alternate displayed part number selection will require you to contact Parker Filtration for Availability

10MFP Series

with Moduflow *Plus*
Portable Filtration Trolley



The ideal way to pre-filter and transfer fluid

Transfer fluid from drums or storage tanks

Using a Parker portable filter trolley is the most economic way to protect your system from the harm that can be caused by contamination. *Option.* Consider specifying an icountPD particle detector to allow accurate detection of particulate when transferring oil.

The CE marked 10MFP filtration trolley will operate with a maximum recommended viscosity of 800 cSt.



Contact Information: Product Features:

Parker Hannifin
Hydraulic Filter Division Europe

**European Product
Information Centre**
Freephone: 00800 27 27 5374
(from AT, BE, CH, CZ, DE, EE, ES,
FI, FR, IE, IT, PT, SE, SK, UK)
filtrationinfo@parker.com

www.parker.com/hfde

- 10MFP hydraulic trolley is the ideal way to pre-filter and transfer fluids into reservoirs or to clean up a system.
- Heavy-duty frame but still lightweight and portable.
- Maximum flow 38 l/min.
- CE marked.
- 10MFP trolley operating viscosity range - use below 800 cSt. (Note: icountPD recommended viscosity level is 108 cSt.)
- Par-Gel water removal elements available.
- icountPD particle detector with MS Moisture Sensor option.

10MFP Series

Portable Filtration Trolley

Applications for Portable Filtration Trolley

- **Filtering new fluid before putting into service**
- **Transferring fluid from drums or storage tanks to system reservoirs**
- **Conditioning fluid that is already in use**
- **Complimenting existing system filtration**
- **Removing free water from a system**
- **For use with fluids such as hydraulic, gear and lube oils**
- **Maximum viscosity is 800 cSt. The icountPD configuration with an online STI size 0 sensor allows a fluid viscosity range of 1 to 108 cSt**

Parker portable filter trolleys are the ideal way to prefilter and transfer fluids into reservoirs or to clean up existing systems.

Fluid should always be filtered before being put into use. New fluid is not necessarily clean fluid. Most new fluids (right out of the drum) are unfit for use due to high initial contamination levels. Contamination, both particulate and water, may be added to a new fluid during processing, mixing, handling and storage.

Water is removed by installing Par-Gel elements in the outlet filter. Par-Gel elements are made from a polymer which has a very high affinity for free water.

Once water comes into contact with this material, it is removed from the system.

The Parker portable filter trolley uses two high capacity ModuFlow Plus filters for long element life and better system protection. The first stage (inlet) filter captures larger particles, while the second stage (outlet) filter controls finer particles or removes water. A rugged industrial quality gear pump gets the job done fast.

Using a Parker portable filter trolley is the most economical way to protect your system from the harm that can be caused by contamination.

Features	Advantages	Benefits
<ul style="list-style-type: none"> • Two filters instead of one w/ 2.5 times increased DHC 	<ul style="list-style-type: none"> • Pump protection and long element life 	<ul style="list-style-type: none"> • Element cost savings and trouble-free service
<ul style="list-style-type: none"> • Wide variety of particulate elements available 	<ul style="list-style-type: none"> • Capable of getting a fluid to a desired cleanliness level 	<ul style="list-style-type: none"> • Extends fluid life and system performance
<ul style="list-style-type: none"> • Par-Gel™ water removal elements available 	<ul style="list-style-type: none"> • Removes “free water” from a system 	<ul style="list-style-type: none"> • Gets dirt and water out of system with one process
<ul style="list-style-type: none"> • Heavy duty frame 	<ul style="list-style-type: none"> • Rugged and durable 	<ul style="list-style-type: none"> • Built to last for many years of use
<ul style="list-style-type: none"> • Lightweight and portable 	<ul style="list-style-type: none"> • Easy to move from place-to-place 	<ul style="list-style-type: none"> • One person operation
<ul style="list-style-type: none"> • 3.35 m hose and wand assemblies included 	<ul style="list-style-type: none"> • Additional hardware not necessary 	<ul style="list-style-type: none"> • Ready to use as received

Features

Hose & wand assembly

- Ready to use
- Flexible hoses for tight spots
- Kink-resistant hose prevents pump cavitation

icountPD

- Independent monitoring of system contamination trends
- ISO code range 7 - 22
- Self diagnostic software
- Moisture sensor [%] RH

Service cover

- Top-accessible for easy changing of elements

Visual indicator

Heavy Duty frame

Dual filters “Moduflow” type

- Two stage, double length filtration for long element life and pump protection

Elements (see ordering information)

- Available for both particulate and Water Removal (WR) options



Gear pump

- Industrial quality
- Quiet operation
- Dependable, long life

Drip tray

- Helps keep the work area safe and clean

Electrical Box

- 10MFP motor/pump current trip limiter set to 240V unit = 3.50 Amps
110V unit = 6.00 Amps

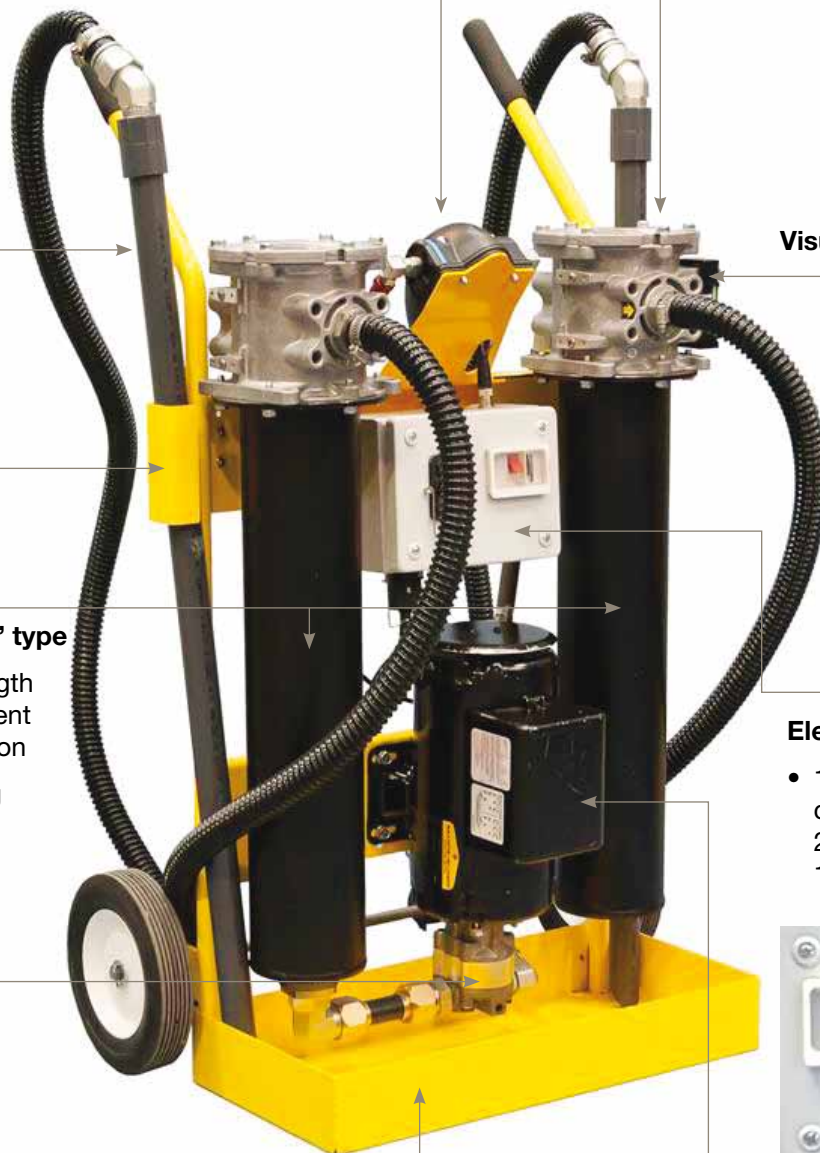

Technical specification

Dimensions (Approx.) (mm / inches)	A - Height : 1029mm / 40.5" B - Width : 648mm / 25.5" C - Depth : 483mm / 19"
Weight (Approx.) (Kg / lbs)	62kg / 137lbs
Principle of operation IPD	Laser diode for optical detection of actual particulates
International codes	ISO 7 - 22
icountPD calibration	By recognised online methods confirmed by the relevant ISO procedures: MTD - via a certified primary ISO 11171 automatic particle detector using ISO 11943 principles, with particle distribution reporting to ISO 4406:1996
icountPD recalibration	Every 12 months: commoninfo@parker.com
Unit Ambient storage temperature	-26°C to +70°C (-79°F to + 158°F)
Unit operating environment	DO NOT use the filtration trolley in wet or damp environmental conditions
Recommended fluid operating viscosity	Up to 108 cSt (500 SUS) (0.85 Specific Gravity)
Filter trolley operating viscosity range	Use below 800 cSt (3880 SUS)

Pump Flow Rate	38 l/min (10 GPM)
1st stage filtration (Suction / Inlet Filter)	Micron rating specified in part number, visual indicator (Optional), 0.2 bar (3 psi) bypass preventing pump cavitation
2nd stage filtration (Pressure / Outlet Filter)	Micron rating specified in part number, visual indicator, 1.7 bar (25 psi) prevents excessive pressures
Suction / Pressure Hose	PVC (Standard, 1 metre (39"))
Suction Pressure Wand	PVC (Standard, 1 metre (39"))
Certification	IP22 rating EN61326-1-2006 Electrical equipment for measurement, control and laboratory EN61029-1-2009 + A11:2010 Modified Safety of transportable motor operated electric tools 2006/42/EC Machinery Directive
Construction	Cart frame = Steel Filter head = Aluminium Filter bowl = Steel Hoses = PVC (std.) Wands = PVC (std.) Steel tube
Electrical Motor	10MFP - ¾ hp@ 3450 rpm, O.D.P. Thermal overload protection.



New feature!

'SmartCart'

A diagnostic filter trolley - the 'SmartCart'. The icountPD particle detector can be mounted to the standard frame of the filter cart for enhanced monitoring of your hydraulic system.

Oil Type versus Recommended Kinematic Viscosity Chart for icountPD operation*.

Oil Type	Kinematic Viscosity @ 40°C in cSt	Kinematic Viscosity @ 30°C in cSt	Kinematic Viscosity @ 20°C in cSt	Kinematic Viscosity @ 10°C in cSt
ISO 7	7	9.5	13	19
ISO 10	10	14	20	32
ISO 15	15	25	35	60
ISO 22	21.6	35	60	108
ISO 32	32.2	55	90	180
ISO 46	46.3	80	140	280
ISO 68	60	120	220	450
ISO 100	96.7	280	350	800
ISO 150	147	300	550	1200
ISO 220	220	400	850	2000

* yellow boxes= the work range of 10MFP and icountPD operation



Typical Fluid Cleanliness Level Requirements

Many manufacturers of hydraulic components have established fluid cleanliness levels for their components. Using a portable filter trolley can be a very effective way to reach and maintain these cleanliness levels.

Component	ISO Cleanliness Level
Servo control valves	16/14/11
Proportional valves	17/15/12
Vane and piston pumps/motors	18/16/13
Directional and pressure control valves	18/16/13
Gear pumps/motors	19/17/14
Flow control valves cylinders	20/18/15
New fluid	20/18/15

Filter Trolley Element Performance

Media Code	Filter Media	Capacity (Grams)
40W	Woven Wire	*
40SA	Synthetic	*
20Q	Microglass III	140
10Q	Microglass III	135
05Q	Microglass III	130
02Q	Microglass III	110

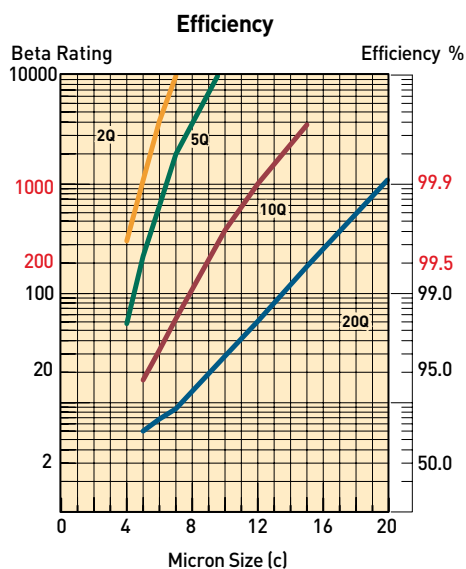

Notes: Multipass test run @ 80 l/pm to 3.5 bar terminal - 5 mg/l BUGL.

Filter Trolley Performance

Fluid cleanliness levels are a function of initial contamination levels, contamination ingress rates, reservoir size and filter element efficiency. The chart below lists approximate time requirements to achieve certain cleanliness levels based on the assumptions noted.

Reservoir Capacity (Litres)	Time Required (Hours)	Projected Cleanliness Level (ISO)
190	0.5	20/18/15
190	1.0	17/15/12
190	2.5	16/14/11
378	1.5	18/16/13
378	2.5	17/15/12
378	4.0	16/14/11
757	2.5	19/17/14
757	3.5	18/16/13
757	5.0	17/15/12

Notes:

The results in the chart are based on the following assumption:

1. Initial contamination level is 500,000 particles greater than 10 micrometers per 100 ml of fluid (10MFP trolley).
2. Inlet filter fitted with 40SA element; outlet with 20Q element.
3. System ingress rate equal to 1×10^6 particles greater than 10 micrometers entering the system per minute.

Par-Gel Media Water Capacity

Model	Fluid Viscosity	Capacity
10MFP	14cSt	500 ml
	43cSt	300 ml

Notes:

1. Par-Gel elements are designed to remove "free water", which is defined as water that is above a particular fluid's saturation level.
2. Capacity is very dependent on flow rate and viscosity. Not recommended with fluids in excess of 108 cSt (500 SUS).



Assembly

1. Install hoses to inlet and outlet filters by threading the hose end with the straight thread o-ring seal fitting into the filter flange.
2. Connect the PVC tube wands to the swivel fitting on the hose end. When servicing the PVC tube wand, do not over-torque the metal fittings going into the PVC coupling. Over-torque will result in cracking the coupling. Generally, 1/4 turn beyond hand-tight is sufficient.

Operating Instructions

1. Insert the inlet wand assembly into the supply fluid receptacle (drum/reservoir). The RFP filter is the inlet filter.
2. Insert the outlet wand assembly into the clean fluid receptacle (drum/reservoir). The ILP filter is the outlet filter.

Caution: Do not kink the hose assemblies, this may result in excessive vacuum or pressure at the pump.

3. Verify that the ON/OFF switch is OFF and plug the cord into the proper grounded power source (3 wire).
4. Turn switch to ON position and check outlet wand for oil flow. Allow 30 to 60 seconds for filters to fill with oil. If repeated attempts to obtain oil flow fail, check pump inlet fittings for tightness, remove inlet filter access cover and verify the cover sealing o-ring is in place. For very viscous fluids it may be necessary to pour 1 or 2 quarts of fluid into the RFP inlet filter housing to prime pump initially.
5. The condition of the filter element should be monitored by observing the cleanliness indicator on the outlet filter. When the indicator is in the CHANGE position, both inlet and outlet filter elements MUST be replaced to prevent fluid from going through the bypass in the filters.

6. The inlet filter element is provided with a 0.2 bar bypass spring, and prevents the pump from cavitating if the element is not changed. The outlet filter element is provided with a 2.4 bar bypass spring to prevent excessive pressure which may be harmful to personnel or to the filter trolley.

Warning: The filter bypass spring acts as a relief valve for the pump. Do not restrict the outlet hose with a shut-off valve which will defeat the function of the bypass valve, causing excessive pressure, which may be harmful to personnel or to the filter trolley.

7. The cleanliness indicator works on differential pressure and will indicate the condition of the element (CLEAN, CHANGE, or BYPASS).

NOTE: The filter trolley must be in operation for the indicator to read properly.

Maintenance Instructions

1. Turn switch to OFF position and unplug cord from electrical outlet.
2. Remove tube wands from oil to prevent siphoning.
3. Loosen hex head screws on filter cover. Turn cover to clear screws, remove cover.
4. Pull filter element from the filter head.

- a) Replace the synthetic or Microglass III elements. Verify replacement.
- b) Wire mesh elements can be cleaned. Ultrasonic cleaners provide best results.

5. Make sure element o-rings seat properly into the head, making sure that the notch on the element lines up with the notch in the head.
6. Inspect the cover o-ring and replace if necessary.
7. Relocate the cover and tighten hex head screws until they are snug. Do not over-torque these screws (Max torque is shown in maintenance leaflet). Do not interchange the inlet filter cover with the outlet filter cover. (The inlet filter has a "RFP" prefix, the outlet filter has a "ILP" prefix).
8. Contact the Parker HFDE regarding IPD calibration.
9. IPD removal: remove oil lines from the IPD at the two fittings closest to the IPD. Disconnect the two cables from the IPD. Remove IPD from trolley via two screws. The trolley can be used without the IPD as long as the sample hoses are removed from the System 20. Protect sampling connectors from contamination.

Trouble Shooting

Problem	Cause	Solution
Does not start	ON/OFF Switch No electrical power Defective motor	Turn switch ON, replace switch if defective Plug in cart Contact service department
No oil flow or erratic pump noise	Filter housing not filled with oil Suction leak Defective pump	Allow pump to run 30 to 60 seconds Check tightness of inlet fittings Check o-ring in inlet filter cover for nicks Kink or restriction in inlet hose Add 1 or 2 quarts of oil to inlet filter Contact service department
Indicator reads CHANGE or BYPASS	Element dirty Oil extremely cold or viscous	Replace or clean elements (both filters) Change element to coarser micron rating
Indicator does not seem to move	No outlet element 40 micron element installed in outlet filter	Install element Check trolley model number to verify correct element. The inlet filter has a rating RFP prefix; the outlet filter has an ILP prefix

Filter Trolley Spare Parts List

(For more information consult Parker)

Part No.	Description	Qty
928690	Frame	1
941468	Frame (SmartCart)	1
940980	Pipe Reducer Fitting	1
940979	Tube Fitting	1
937526	Suction Tube Assy.	1
928652	Adapter Fitting	1
928731	Pump	1
940977	Adapter Fitting	1
928650	Wheel	2
928653	Axle	1
928678	Motor 10MFP	1
937527	Discharge Tube Assy.	1
941467	Discharge Tube Top (SmartCart)	1
941466	Discharge Tube Bottom (SmartCart)	1
STI.0144.100	System 20 (SmartCart)	1
3/8-8F40HG5S	System 20 Fitting 1 (SmartCart)	2

Part No.	Description	Qty
12/8 F50X-S	System 20 Fitting 2 (SmartCart)	2
940978	Tube Fitting	1
928623	Cord Reel	1
940960	Inlet Filter – Nitrile	1
941024	Inlet Filter – Fluorocarbon	1
928784	Tube Wand Assy. – Seal Option B	2
940961	Outlet Filter – Nitrile	1
941025	Outlet Filter – Fluorocarbon	1
928663	Hose Assy. – Seal Option B	2
928651	Handle Grip	2
See Chart**	Element, (1) Inlet & (1) Outlet	2
See Chart**	Icount PD	1
ACC6NN014	Icount Cable	1
ACC6NH001	Icount Hoses	2
ACC6NW009	Icount Fitting 2	2

**Refer to chart on the ordering information page.

Ordering Information

Standard Products Table - icount PD fitted option

Part Number	Model	Motor Option	Inlet element	Outlet element	Filter bowl length	Electrical plug type	Standard fitted elements	
							Inlet	Outlet
10MFP140SA10Q1UKPD	10MFP	1*	40 SA	10Q	1	UK	940802	937399Q
10MFP140SA10Q1EURPD	10MFP	1*	40 SA	10Q	1	EUR	940802	937399Q
10MFP240SA10Q1INDPD	10MFP	2*	40 SA	10Q	1	IND**	940802	937399Q

Standard Products Table - Standard trolley specification

Part Number	Model	Motor Option	Inlet element	Outlet element	Filter bowl length	Electrical plug type	Standard fitted elements	
							Inlet	Outlet
10MFP140SA10Q1UK	10MFP	1*	40 SA	10Q	1	UK	940802	937399Q
10MFP140SA10Q1EUR	10MFP	1*	40 SA	10Q	1	EUR	940802	937399Q
10MFP240SA10Q1IND	10MFP	2*	40 SA	10Q	1	IND**	940802	937399Q

Note 1: Motor options* Option 1 = 220/240 VAC. Option 2 = 110 VAC.

Note 2: Plug Type** IND = industrial 110 VAC UK option.

Note 3: PD = icountPD, type IPD12322230.

Note 4: Standard items (Part number shown in bold type) are in stock.

Replacement filter element part numbers

Parker Moduflow Plus inlet filter (suction) 0.2 bar bypass	Nitrile
20µ Microglass III element	940971Q
40µ synthetic element	940802
40µ stainless steel element	940803

Parker Moduflow Plus outlet filter (pressure) 2.4 bar bypass	Nitrile
2µ Microglass III element	937397Q
5µ Microglass III element	937398Q
10µ Microglass III element	937399Q
20µ Microglass III element	937400Q
Water removal element	940734

Accessory part numbers

Description	Reference	Part Number
Mains cable (UK 2m cable, 230V~)		ACC6JE001
Mains cable (EUR 2m cable, 230V~)		ACC6JE002
N72530 Filter cover O-ring replacement (x2)		ACC6NX003

Description	Reference	Part Number
10MFP UK extension reel length 7.5m	Contact Parker	ACC6JE004
10MFP EUR extension reel length 7.5m	Contact Parker	ACC6JE005

PVS Series - Models 185, 600, 1200, 1800 and 2700

Portable Purification Systems



Reduce the catastrophic results of water contamination

Eliminate water from the hydraulic system

The PVS Series Portable Purification Systems, available in several models, is used to draw water contaminated fluid out of a system, remove the water content and return the 'clean' fluid to the reservoir. Maximum flow 170 l/min (PVS2700). Reduce the catastrophic results of water contamination.



Contact Information:

Parker Hannifin
Hydraulic Filter Division Europe

European Product Information Centre
Freephone: 00800 27 27 5374
(from AT, BE, CH, CZ, DE, EE, ES, FI, FR, IE, IT, PT, SE, SK, UK)
filtrationinfo@parker.com

www.parker.com/hfde

Product Features:

- PVS draws water contaminated fluid out of a system.
- Removes water, air and particulate content and returns the 'clean' fluid to the reservoir.
- Maximum flow 170 l/min (PSV2700).
- Reduce the catastrophic results of water contamination.

PVS Series

Portable Purification Systems

Effects of Water Contamination

Water is one of the most common and destructive contaminants in a fluid system. When water contaminates a system, it can cause serious problems such as:

- Corrosion by etching metal
- Fluid breakdown, reduction of lubricating properties, additive precipitation, and oil oxidation
- Reduced dielectric strength
- Abrasive wear in hydraulic components

Typical saturation points		
Fluid type	PPM	%
Hydraulic fluid	300	.03%
Lubrication fluid	400	.04%
Transformer fluid	50	.005%

Free water occurs when oil becomes saturated and cannot hold any more water. This water is usually seen as cloudy oil or puddles of water at the bottom of an oil reservoir. Water which is absorbed into the oil is called dissolved water. At higher temperatures, oil has the ability to hold more water in the dissolved stage due to the expansion of oil molecules. As the oil cools, this ability reverses and free water will appear where not visible before. In addition to temperature, fluid type also determines the saturation point for your system (see chart above).

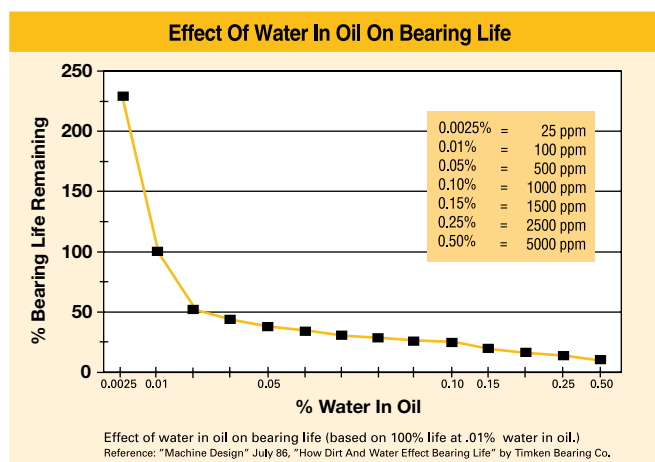

Principles of Operation

Contaminated oil is drawn into the Parker portable purification system by a vacuum of 25 In/Hg. The oil passes through the in-line low watt density heater/s where the oil is heated to an optimum temperature of 66°C (150°F).

The oil then enters the distillation column where it is exposed to the vacuum through the use of dedicated dispersal elements. This increases the exposed surface area of the oil and converts the water to a vapor form, which is then drawn through the condenser by the vacuum pump. The vapour returns to water and drops into the condensate holding tank - this can then be drained off at a later stage.

The water-free oil falls to the bottom of the vacuum chamber and is passed through a final particulate removal filter by a heavy duty lube oil pump.

Clean dry oil re-enters the reservoir/system via the outlet port.

Applications for PVS Portable Purification Systems

- **Paper mills**

- Dryer lubrication
- Hydraulic
- Compressor lubrication
- Calenders

- **Steel mills**

- Bearing lubrication
- Continuous casters
- Press roll lubrication

- **Power generation**

- Turbine oil
- Transformer oil
- EHC systems

- **Industrial/aerospace**

- Test stands
- Machine tools

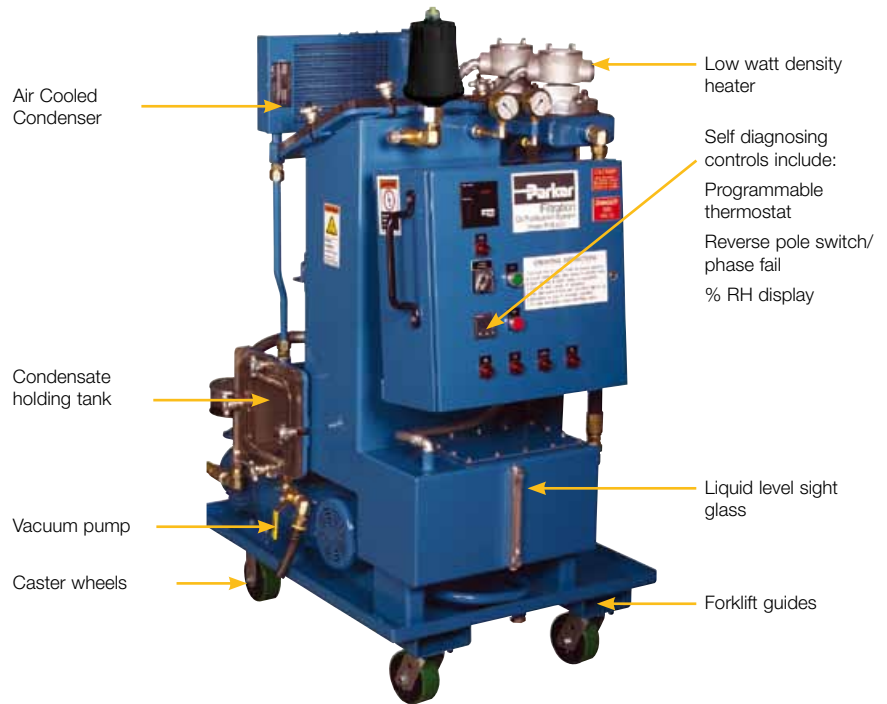

Features	Advantages	Benefits
Variable flow circuit	Allows oil to heat to required temperature quickly	Starts removing water quickly
Moisture sensor	Real-time water content indication	Indicates when safe water content level is obtained
Condensate holding tank	Captures removed water/solvents Large enough to provide long service interval	Eliminate potential hazard of exhausting to atmosphere Reduced maintenance costs
Compact size	Smallest envelope in the industry Ease of portability	Fits through doorways and down narrow aisles Increased use
Forklift guides Lifting eyes	Provides safe and secure method to lift unit	Employee safety Easily transported
Programmable thermostat	Maintains oil within 1°C Prevents overheating oil	Unattended operation Increases oil life
Automatic operation	Unattended use	Reduced labour costs Increased running time
Reverse pole switch/phase fail	Change motor rotation for different power source locations	Flexibility, less maintenance Prevents incorrect rotation
High temperature safety circuit	Shuts down heater if primary contactors fail Oil can never exceed 120°C (250°F)	Prevents system damage Worker safety
Circuit breakers utilised in electrical panel	No fuses to replace Simple diagnostics	Fewer spare parts, increased uptime Reduced maintenance
Available with EPR seals and stainless steel	Phosphate ester compatible	Specifically designed for application
Solid state heater contactor	Longer more reliable service life	Reduced downtime

PVS Series

Portable Purification Systems

Potential contaminant	PVS performance
Solid particulate 14/13/10 attainable	ISO cleanliness code*
Water 80-90% of dissolved water.	Removes 100% of free water,
Air 90% of dissolved air.	Removes 100% of free air,
Gases 90% of dissolved gases.	Removes 100% of free gases,

* When utilising 2Q media

PVS (Vacuum dehydration) compared to other technologies

Centrifuge units – Removes free water only; has difficulty breaking stable emulsions; larger envelope dimensions but lower flows; higher initial and operating costs.

Desiccant units – Have limited water removal capability due to absorbing material; only removes air ingressed particles; expensive compared to the volume of water removed.

Coalescer units – Removes free water only; has difficulty breaking stable emulsions; does not work well in viscous fluids (>23cSt); much larger in size compared to PVS.

Typical Performance

Tank size	227 litres (50 gallons)
Run time	62 minutes
Parker model	PVS 600 (37.9 l/min)
Water content (ppm)	Start: 10,000 PPM (1.0%) Stop: 50 PPM(0.005%)
Contamination level	Start: ISO 21/18/16 Stop: ISO 16/14/11



Start



Stop

Estimated Water Removal Time 5000 ppm (0.5%) to 150 ppm (0.015%)

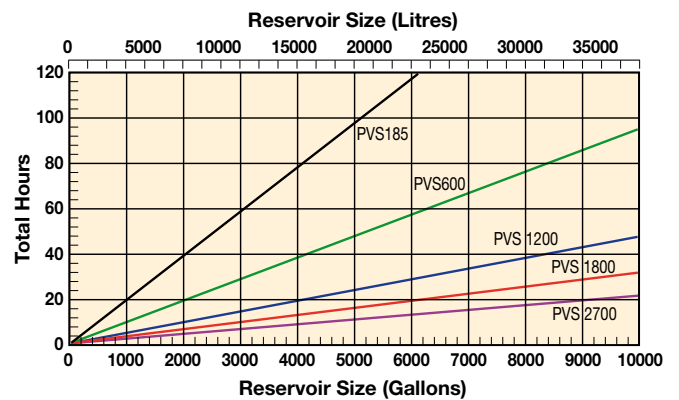

PVS 185

Portable Purification Systems

Specification

Flow rate:
19 lpm (4.2 gpm).

Height:
1651mm (65").

Width:
825.5mm (32.5").

Length:
1206.5mm (47.5").

Weight:
294.8 kg (650 lbs).

Seal material:
Fluorocarbon (EPR opt.).

Condensate tank:
15.5 ltrs (3.4 gals).

Dispersal elements:
1.

Minimum operating capacity:
18.9 ltrs (4.2 gals).

Vacuum (max):
25 In/Hg.

Viscosity (max):
108 cSt (500sus) – disposable.
460 cSt (2150 sus) – packed tower.

Outlet pressure (max):
4.1 bar (60 psi).

Ports:
3/4" JIC (male) inlet.
3/4" JIC (male) outlet.

FLA (full load amps):
15-41 amps.
(Depending on voltage used).



Replacement elements

Standard Coreless Particulate 80CN-2

02QE	(2 micron)	936716Q
05QE	(5 micron)	936717Q
10QE	(10 micron)	936718Q
20QE	(20 micron)	936719Q

Option Coreless Particulate IL8-3

02QE	(2 micron)	933734Q
05QE	(5 micron)	933612Q
10QE	(10 micron)	933735Q
20QE	(20 micron)	933736Q

Dispersal

Disposable (Coalescing)	933180
Packed tower (Cleanable)	933553

PVS 185 flow diagram

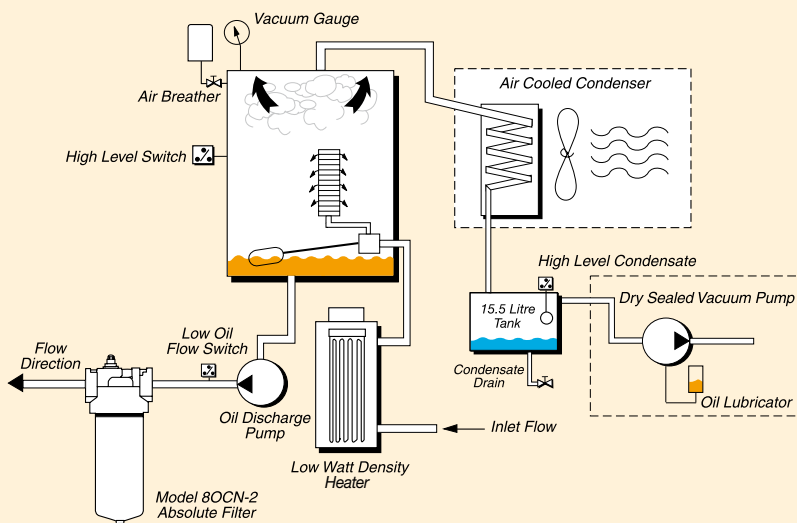

PVS 600

Portable Purification Systems

Specification

Flow rate:

38 lpm (8.3 gpm).

Height:

1638.3mm (64.5").

Width:

1117.6mm (44").

Length:

1549.4mm (61").

Weight:

408.2 kg (900 lbs).

Seal material:

Fluorocarbon (EPR opt.).

Condensate tank:

15.5 ltrs (3.4 gals).

Dispersal elements:

2.

Minimum operating capacity:

22.7 ltrs (5.0 gals).

Vacuum (max):

25 In/Hg.

Viscosity (max):

108 cSt (500sus) – disposable.

460 cSt (2150 sus) – packed tower.

Outlet pressure (max):

4.1 bar (60 psi).

Ports:

1" JIC (male) inlet.

1" JIC (male) outlet.

FLA (full load amps):

24-38 amps.

(Depending on options & voltages).



Replacement elements

Standard Coreless Particulate 80CN-2

02QE	(2 micron)	936716Q
05QE	(5 micron)	936717Q
10QE	(10 micron)	936718Q
20QE	(20 micron)	936719Q

Option Coreless Particulate IL8-3

02QE	(2 micron)	933734Q
05QE	(5 micron)	933612Q
10QE	(10 micron)	933735Q
20QE	(20 micron)	933736Q

Dispersal

Disposable (Coalescing)	933180
Packed tower (Cleanable)	933553

PVS 600 flow diagram

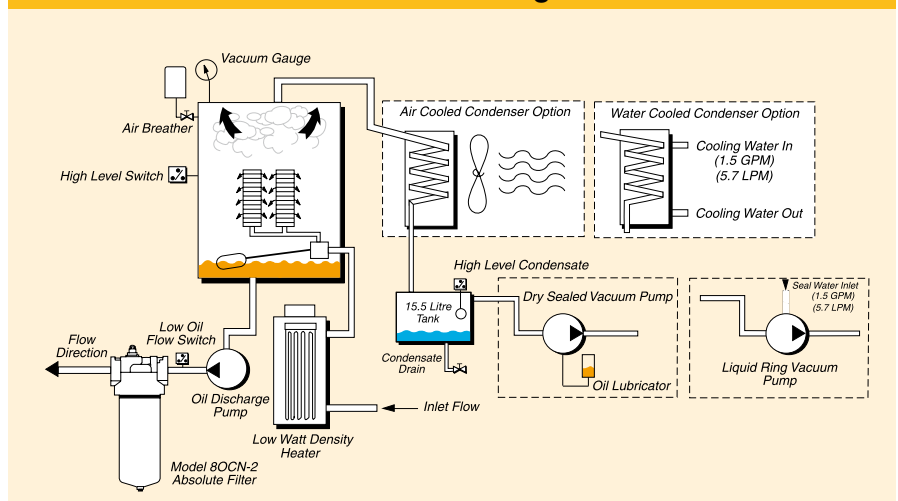

PVS 1200

Portable Purification Systems

Specification

Flow rate:
76 lpm (16.7 gpm).

Height:
1651mm (65").

Width:
1117.6mm (44").

Length:
1549.4mm (61").

Weight:
703.1 kg (1550 lbs).

Seal material:
Fluorocarbon (EPR opt.).

Condensate tank:
31.4 ltrs (6.9 gals).

Dispersal elements:
4.

Minimum operating capacity:
41.6 ltrs (9.1 gals).

Vacuum (max):
25 In/Hg.

Viscosity (max):
108 cSt (500sus) – disposable.
460 cSt (2150 sus) – packed tower.

Outlet pressure (max):
4.1 bar (60 psi).

Ports:
1 1/2" NPTF inlet.
1" JIC (male) outlet.

FLA (full load amps):
30-48 amps.
(Depending on options & voltages).



Replacement elements	
Coreless IL8-3	
02QE	933734Q
05QE	933612Q
10QE	933735Q
20QE	933736Q
Dispersal	
Disposable (coalescing)	933180
Packed tower (cleanable)	933553

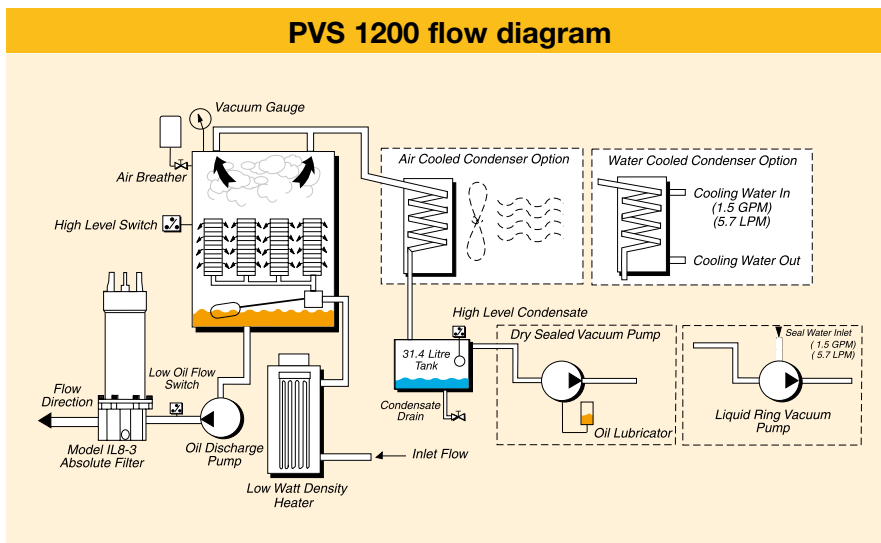

PVS 2700

Portable Purification Systems

Specification

Flow rate: 170 lpm (37.4 gpm).	Minimum operating capacity: 68.1 ltrs (14.98 gals).
Height: 1651mm (65").	Vacuum (max): 25 In/Hg.
Width: 1066.8mm (42").	Viscosity (max): 108 cSt (500sus) – disposable. 460 cSt (2150 sus) – packed tower.
Length: 1943.1mm (76.5").	Outlet pressure (max): 4.1 bar (60 psi).
Weight: 1156.7 kg (2550 lbs).	Ports: 3" NPTF inlet. 2" NPTF outlet.
Seal material: Fluorocarbon (EPR opt.).	FLA (full load amps): 50-70 amps @ 460 V/60hz.
Condensate tank: 31.4 ltrs (6.9 gals).	
Dispersal elements: 8.	



Replacement elements	
Coreless IL8-3	
02QE	933734Q
05QE	933612Q
10QE	933735Q
20QE	933736Q
Dispersal	
Disposable (coalescing)	933180
Packed tower (cleanable)	933553

PVS Specification Worksheet - Section 2

10. Water supply temperature: (liquid ring model)
 - Min°F/°C
 - Max°F/°C
 - Normal.....°F/°C
11. Operating environment above/below sea level: Ft./metres
12. Voltage Options: 230Vac, 3p, 60Hz (185,600)
 - 380Vac, 3p, 50Hz (185,600,1200,1800,2700)
 - 460Vac,3p,60Hz (185,600,1200,1800,2700)
 - 575vac, 3p 60Hz (185,600,1200,1800,2700)
13. Available amperage:.....
14. System volume:
15. Special requirements:
16. Any previous filtration problems with application:
17. PVS model selected:

Specification sheet must be completed before order can be entered

PVS Range

Portable Purification Systems

Ordering Information

Product configurator

Select the desired symbol (in the correct position) to construct a model code.

Box 1	STD	Box 2	Box 3	Box 4	Box 5	Box 6	Box 7	Box 8	Box 9
-	PVS	600	460	DS	D	10QE	12	AC	CEPDL

Box 1

Seals	
Description	Code
Fluorocarbon	None
EPR	E8

Box 2

Flow rate	
Description	Code
19 lpm (4.2 gpm)	185
38 lpm (8.3 gpm)	600
76 lpm (16.7 gpm)	1200
114 lpm (25.0 gpm)	1800
170 lpm (37.4 gpm)	2700

Box 3

Power supply		
Model	Description	Code
185	380VAC, 3P, 50HZ	380
	460VAC, 3P, 60HZ	460
	575VAC, 3P, 60HZ	550
600	380VAC, 3P, 50HZ	380
	460VAC, 3P, 60HZ	460
	550VAC, 3P, 60HZ	550
1200	380VAC, 3P, 50HZ	380
	460VAC, 3P, 60HZ	460
	550VAC, 3P, 60HZ	550
1800	380VAC, 3P, 50HZ	380
	460VAC, 3P, 60HZ	460
	550VAC, 3P, 60HZ	550
2700	380VAC, 3P, 50HZ	380
	460VAC, 3P, 60HZ	460
	550VAC, 3P, 60HZ	550

Box 4

Vacuum pump	
Pressure setting	Code
Dry sealed	DS
Liquid ring	LR

Box 5

Dispersal element	
Description	Code
Disposable (coalescing)	D
Packed tower (cleanable – for use with viscous or highly contaminated fluids)	P

Box 6

Particulate element µm (c)	
Description	Code
2 micron Microglass III	02QE
5 micron Microglass III	05QE
10 micron Microglass III	10QE
20 micron Microglass III	20QE

Note: Above elements are rated for Beta 200+ (99.5% efficiency)

Box 7

Heater		
Model	Description	Code
185	12 KW (3 phase)	12
600	12 KW	12
	24 KW	24
1200	24 KW	24
1800	36 KW	36
2700	48 KW	48

Box 8

Condenser	
Description	Code
Air cooled	AC
Water cooled (External water)	LC
Air and water cooled	BC

Box 9

Options	
Description	Code
Standard	None
Pneumatic wheels	PNW
5" Dia. wheels	5DW
Auto condensate drain	ACD
Dirty filter light	DFL
Resetable hour meter	RHM
Sight flow indicator	SFI
Inlet control valve	ICV
CE marked	CE
Differential pressure gauge	DPG
3HP High viscosity circuit	3HP
Condensate drain counter	CDC
Cable reel	CR
Explosion Proof (Class 1, Div. 2, Zone 1&2)	EX2
Upgrade to IL8-3 coreless filter*	IL8
icountPD with LED display	PD
icountPD with LCD display	PDL

Note 1: Contact parker for part number profile availability

Note*: IL8 option available on 185 & 600 models and is standard on 1200 models and larger.

